

MIGLIARI

ALLUMINIO

SRL

**UFFICI: Via Correggio, 48
20149 MILANO
TEL.02/48005365 - 4985355
FAX 02/48194607**



**MAGAZZINO: Via F.lli Wright 10/12
20019 SETTIMO MILANESE
TEL. 02/48915615 - 48915689
FAX 02/4597930**

MIGLIARI

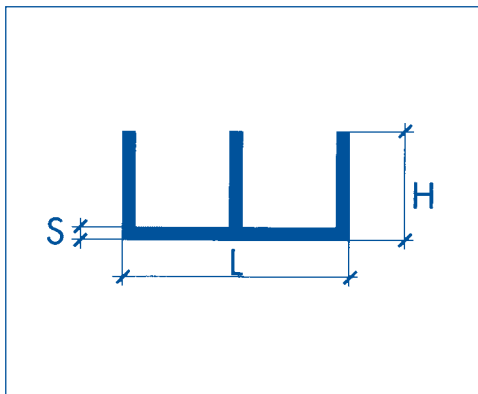

CANALINI DOPPI

UNI 6060-9006 Parte I

DIMENSIONE in mm	Kg/mt
7 x 14 x 7 x 1	0,090
8 x 18 x 8 x 1,2	0,130
10 x 20 x 10 x 1,5	0,151

DIMENSIONE in mm	Kg/mt
15,5 x 20,5 x 15,5 x 1,5	0,250
20 x 20,5 x 20 x 1,2	0,255

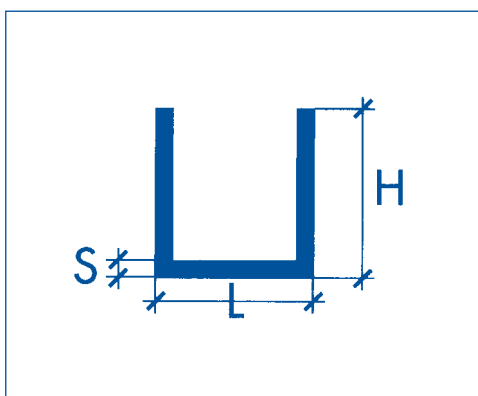

CANALINI (a base stretta)

UNI 6060-9006 Parte I

DIMENSIONE in mm	Kg/mt
15 x 10 x 15 x 1,5	0,150
20 x 10 x 20 x 1,5	0,190
20 x 10 x 20 x 2	0,260

DIMENSIONE in mm	Kg/mt
30 x 15 x 30 x 2	0,385
30 x 20 x 30 x 2	0,421

T
E
U



UNGHETTE PIENE

UNI 6060-9006 Parte I

DIMENSIONE in mm	Kg/mt
6 x 13 x 1	0,065
7 x 18 x 1,5	0,800
7 x 25 x 1	0,095

DIMENSIONE in mm	Kg/mt
7 x 30 x 1,5	0,162
7 x 33 x 1,1	0,120
7 x 40 x 1,1	0,135

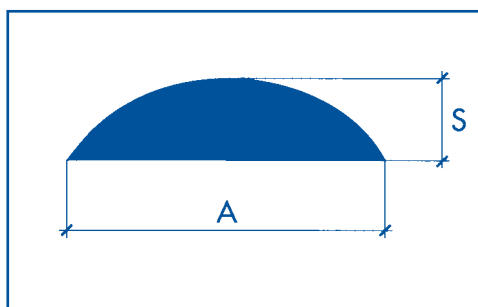

BARRA ANTICORODAL SEMITONDO

UNI 6060-9006 Parte I

DIMENSIONE in mm	Kg/mt
3 x 15	0,085
3 x 25	0,155
5 x 15	0,115

DIMENSIONE in mm	Kg/mt
5 x 20	0,155
5 x 25	0,230
5 x 30	0,220



NASTRI IN ROTOLI

ALTEZZA 1000 MM

SPESSORI DA 0,5 A 1,5 MM

STATO H18 - H32

ALLUMINIO 99,5% - UNI 4507-9001 Parte II

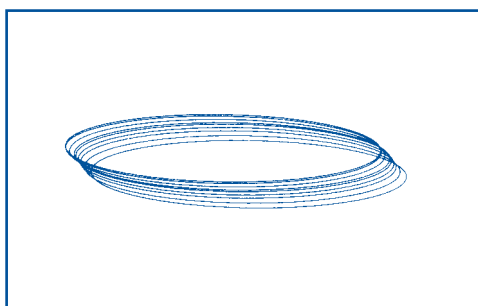

FILO ALLUMINIO

99,5% UNI 4507 - 9001 Parte II

IN MATASSE DA mm 1 A mm 12

COTTO E CRUDO

